

DVMX
Between-Bearings,
Multistage, Axially Split
Pump

BB3 Type *API-610, 10th edition*
ISO 13709

MARELLI

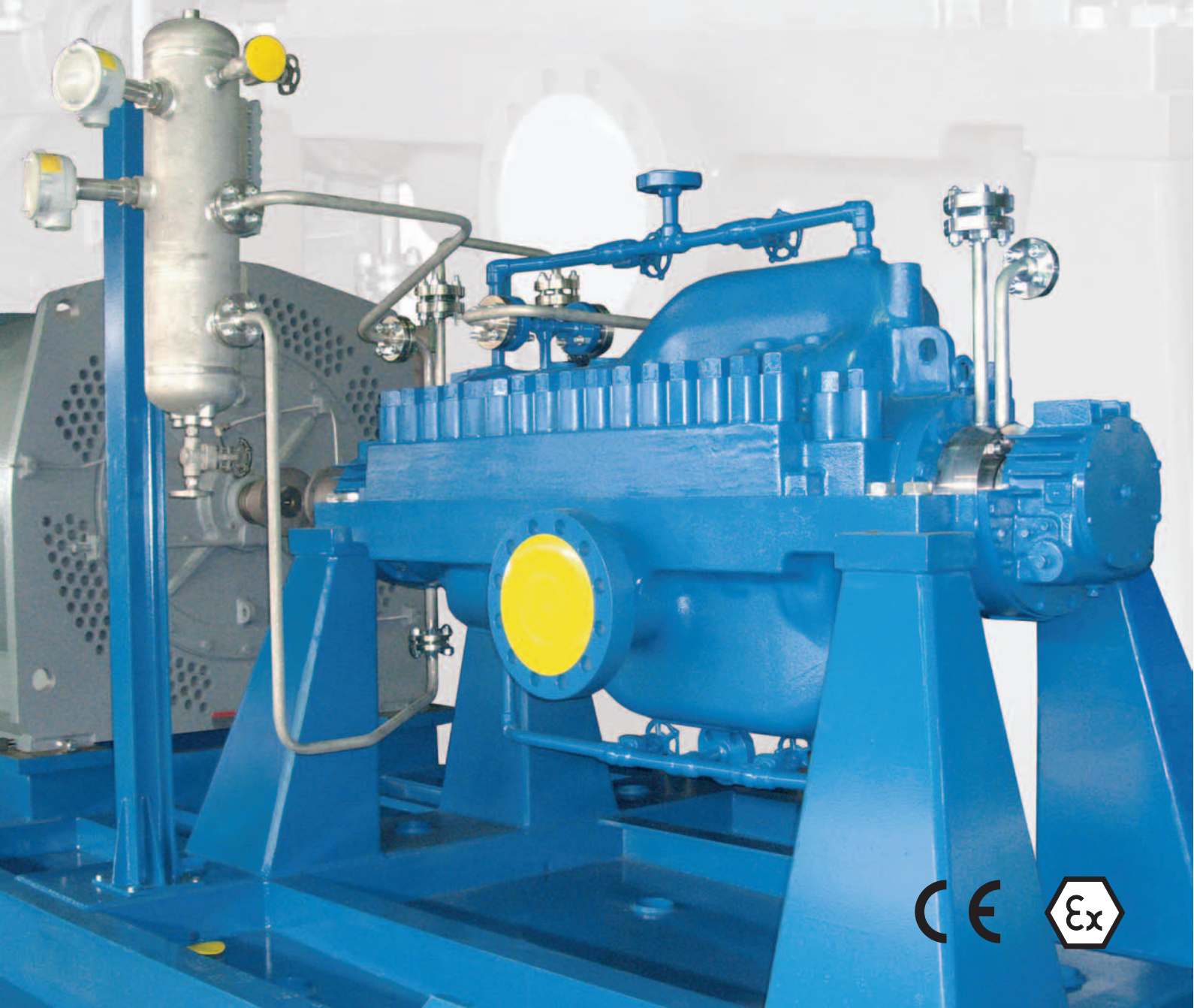

Sundyne Marelli

More than 40 years of experience in centrifugal pump design, development, manufacturing and service, to fulfill the latest standards for petroleum, petrochemical process and heavy duty processing industries, as full compliance machinery.

Applications

Sundyne Marelli, develops tailor made solutions for the high-pressure movement of water, hydrocarbon, CO2 and other process liquids. Our solutions meet the most stringent customer specifications for the following heavy industries:

- ▶ Refineries
- ▶ Desalination plants
- ▶ Water injection platforms
- ▶ Power plants
- ▶ Boiler-feed water in cogeneration
- ▶ Mine de-watering
- ▶ Process charge
- ▶ De-scaling
- ▶ Condensate extraction
- ▶ CO2 injection
- ▶ Process transfer
- ▶ Petrochemical plants
- ▶ Crude oil and gas pipelines
- ▶ Oil fields and terminals
- ▶ Off-shore and on-shore installations for petroleum and gas
- ▶ Reverse osmosis
- ▶ Synfuels
- ▶ High pressure heavy-duty industry applications
- ▶ Other intensive high-pressure services and systems, that demand high reliability and efficient equipment

Design

Sundyne Marelli DVMX BB3 type pump series are horizontal axial split case multi-stage pumps with opposed mounted impellers running in heavy duty double volute casings, nearly centerline mounted, that complies with API-610 10th edition / ISO 13709 standards.

Operating Data

- ▶ Capacities: up to 1800m³/hr (8000 usgpm)
- ▶ Heads: up to 2160 meters (7100 feet)
- ▶ Max Working Pressure: up to 275 bar (4000 psi)
- ▶ Temperature Range: up to 210 °C (410 °F)
- ▶ Rotational speed: up to 6000 RPM
- ▶ Specific Gravity: greater than 0.70

Materials

PART	According to Table H1 - API-610 10th Edition						
	S1	S5	S6	S8	C6	A8	D1
Pressure Casing	Carbon Steel (A216 WCB)				12% CHR	316 AUS	Duplex
Impeller	Cast Iron	Carbon Steel	12% CHR	316 AUS	12% CHR	316 AUS	Duplex
Wear Rings	Cast Iron	12% CHR Hardened		Hard-faced 316 AUS	12% CHR Hardened	Hard-faced 316 AUS	Hard-faced Duplex
Shaft	Carbon Steel	AISI 4140		316 AUS	12% CHR	316 AUS	Duplex
Bearing Housing	Carbon Steel (A216 WCB)						

* Super Duplex Stainless Steel and Monel Materials available

OTHER MATERIALS AND METALURGIES AVAILABLE UPON REQUEST



Standard Features and Benefits

- API-610, 10th Edition / ISO 13709 Full Compliance for reliability and accountability.
- Near-centerline mounted pump casing maintains alignment during operation at elevated temperatures.
- Opposed impeller design for balanced axial thrust for optimal seal and bearing life.
- Single suction closed impeller, with large suction eye for low NPSH requirements.
- Side-Side nozzle arrangement. Nozzles are cast integrally with lower casing half for easy disassembly without disturbing auxiliary pipe work.
- Balancing line design for equalizing pressure in seal chambers for optimal seal life.
- Highly maintainable and easily replaceable wear rings to reduce overall life cycle costs (LCC).
- Ring Oil Lubrication System that incorporates a constant level oiler and a sight glass.
- Dual volute for balancing radial thrust at each stage and for optimizing seal and bearing life.
- Cartridge type mechanical seals for easy assembly and proper installation.
- Dynamic flows analysis assures stable performance and high efficiency levels, with high mechanical reliability.
- Seal chamber in compliance with API-682 3rd Edition / ISO 21049, ready to accommodate single, tandem or double mechanical seals.
- Casings supplied under ASME B16.5 class 600, 900 and 1500.
- Cap Nuts are arranged on the top half casing parting flange, allowing easy casing removal for rotor inspection and ease of maintenance.
- Extra large shaft diameter design to minimize deflection in operation.
- Choice of multiple impellers in each hydraulic pump casing for optimum efficiency over a wide operating range.
- A variety of instrumentation options are available for monitoring all key operating parameters (temperature, pressure, vibrations, etc.).
- Socket welded, flanges drains and vents as standard. Gussets and bracing are also available.
- Labyrinth bearing seals, deflector, to avoid external contamination and maximizing seal and lubrication life.

Seals Chamber. Designed to API 610 / ISO 13709. Ready to fit cartridge seals under API-682 / ISO 21049.

Thrust bearings. Designed with brass cage and double angular contact bearing.

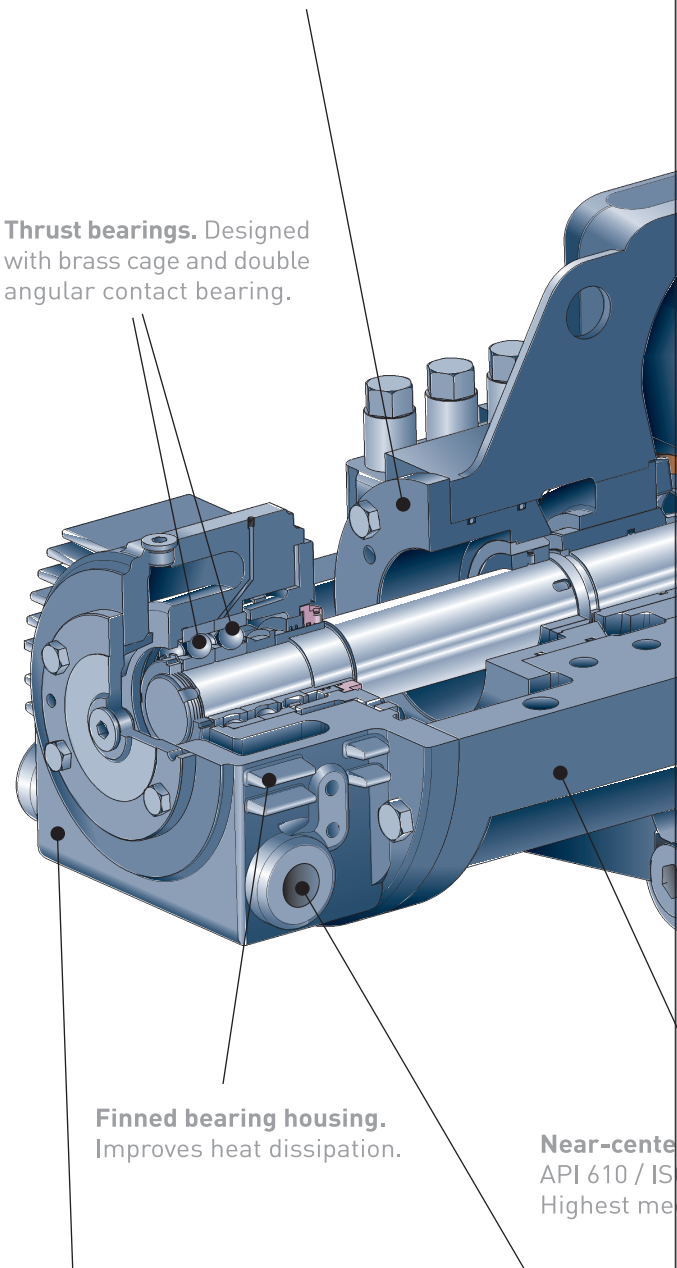

Finned bearing housing. Improves heat dissipation.

Bearing housing. Multiple sizes available to meet load requirements.

Near-centerline
API 610 / ISO 13709
Highest mechanical efficiency

Heat exchanger. To improve heat dissipation.

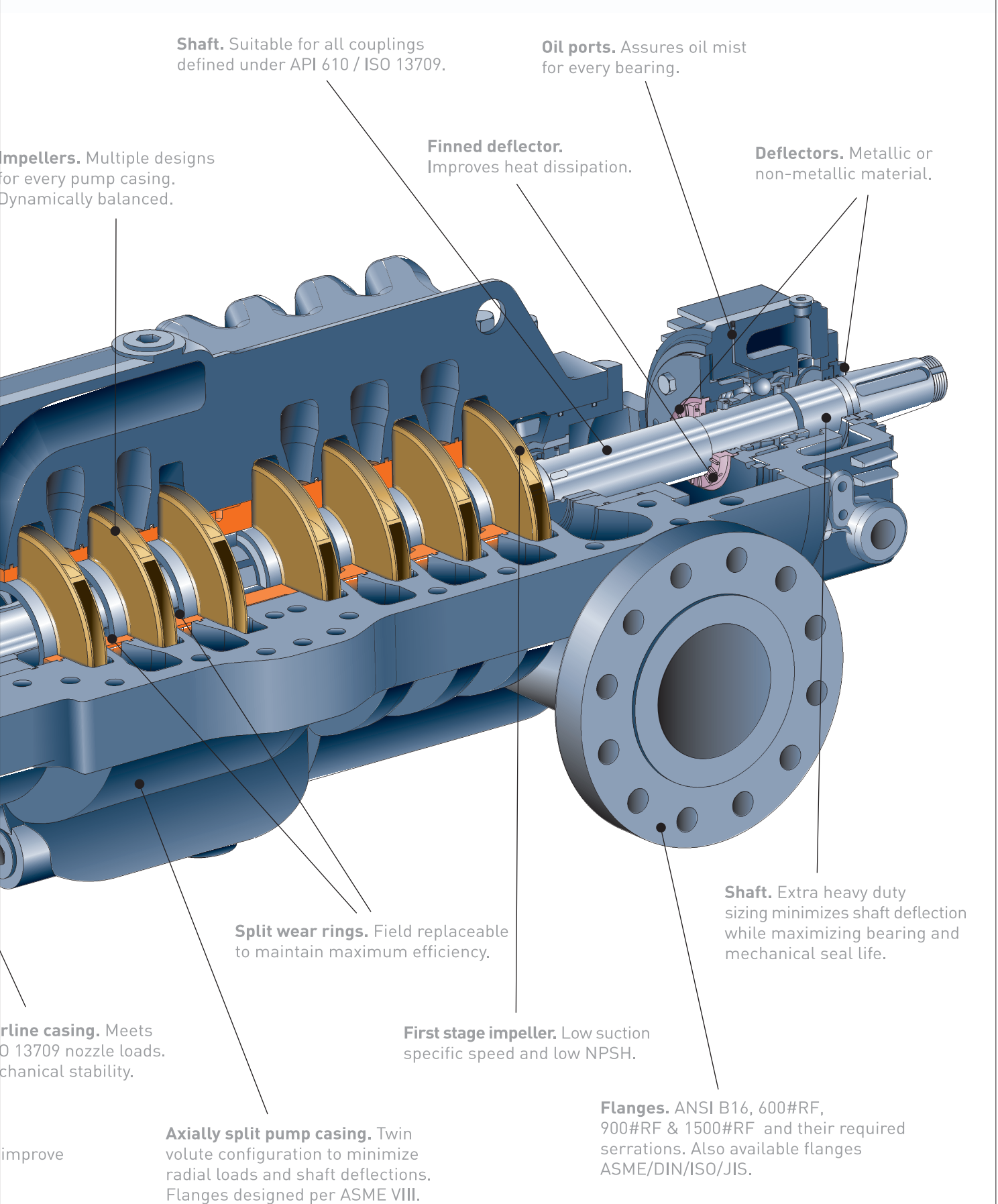

Shaft. Suitable for all couplings defined under API 610 / ISO 13709.

Oil ports. Assures oil mist for every bearing.

Impellers. Multiple designs for every pump casing. Dynamically balanced.

Finned deflector. Improves heat dissipation.

Deflectors. Metallic or non-metallic material.

Line casing. Meets ISO 13709 nozzle loads. Mechanical stability.

Split wear rings. Field replaceable to maintain maximum efficiency.

First stage impeller. Low suction specific speed and low NPSH.

Shaft. Extra heavy duty sizing minimizes shaft deflection while maximizing bearing and mechanical seal life.

Axially split pump casing. Twin volute configuration to minimize radial loads and shaft deflections. Flanges designed per ASME VIII.

Flanges. ANSI B16, 600#RF, 900#RF & 1500#RF and their required serrations. Also available flanges ASME/DIN/ISO/JIS.

improve

Optional Features

Sundyne Marelli provides the DVMX pump series with a range of customized features, to meet specific application requirements.

For High Temperature

- Cooled mechanical seal chamber.
- External cooling for bearing housing with finned heat exchanger fed with inert fluid and/or water.
- Convection venting for bearing housing with a low noise fan placed at rear in coupling side.

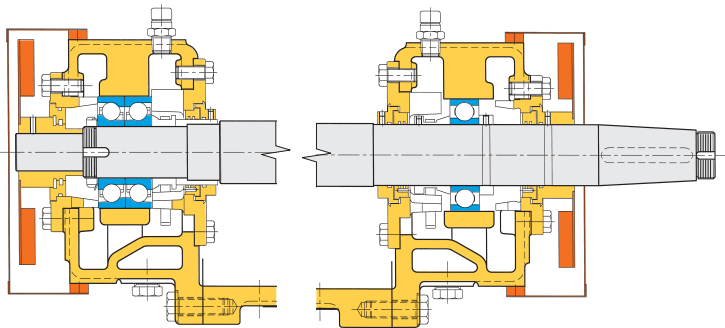
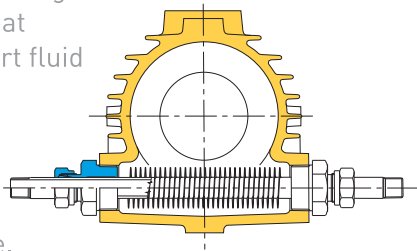

For Lubrication System

- Purge ports with valve. Test gauges for condition analysis.
- Oil mist lubrication system, with purge ports, is outboard for assuring mist flow through each bearing.

Baseplate Designs

- Pre-grouted and non-grouted for all driver types.
- Special base designs to match oversize drivers or pumps.
- Tailor made baseplates are available.
- Skid mounting and oil field types available.

Sundyne Marelli DVMX Series

Precision engineered pumps meeting rigorous customer requirements in a multitude of applications, while reducing the total life cycle cost (LCC) and improving MTBM.

For High Suction Pressure

- Heavy duty bearing housings designed for high suction pressure applications.
- Mechanical seals to meet safety and environmental requirements.
- Engineered bearing solutions are available.

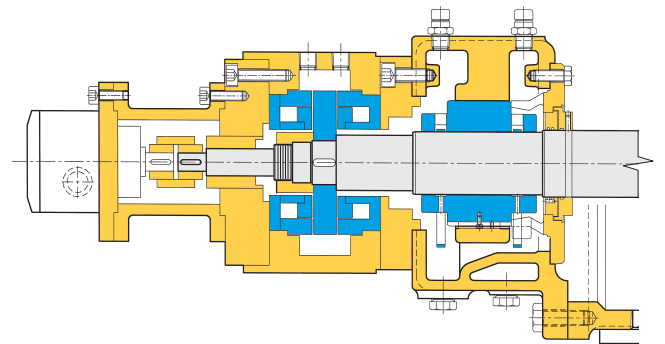

Other Available Solutions

- Double suction, first stage impeller available for obtaining low suction specific speed and low NPSH.
- Optional bearing configurations available, such as split sleeve radial and ball thrust or split sleeve radial and tilting pad thrust.

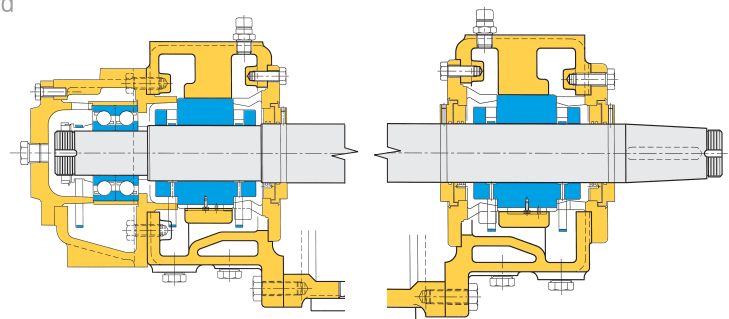

Performance Curves

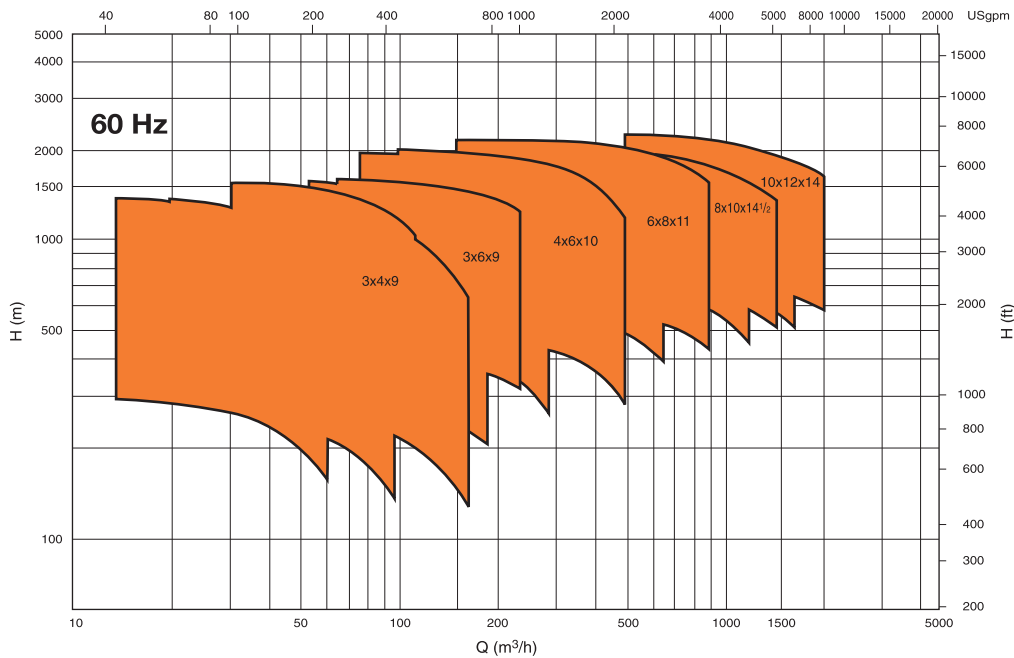
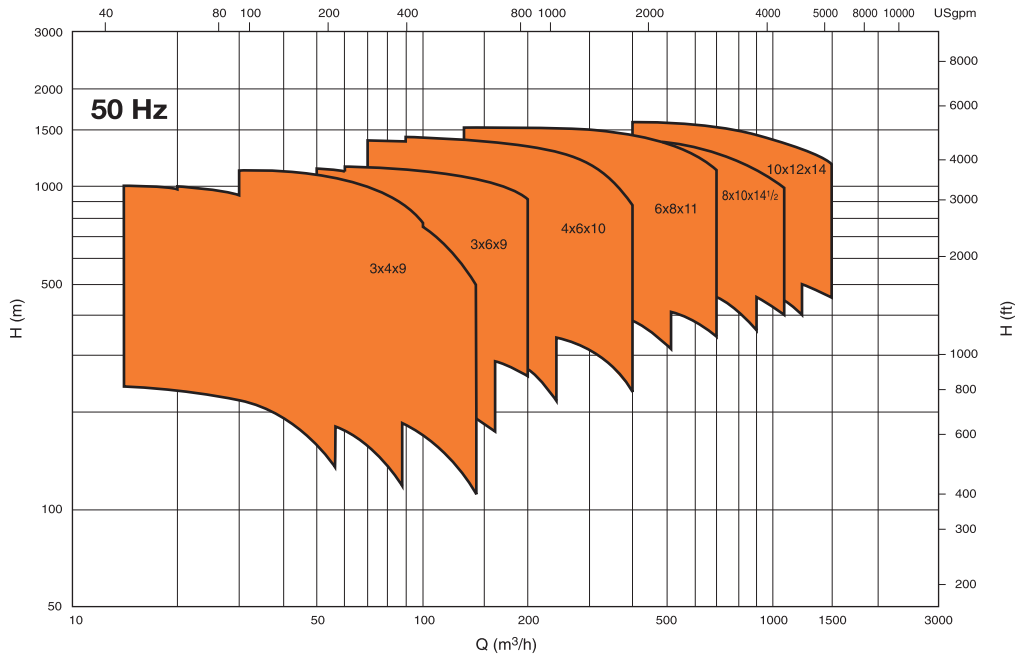

PUMPS

COMPRESSORS

ELECTROMAGNETICS

GENUINE PARTS

SERVICE

Worldwide Headquarters

Sundyne Corporation
14845 West 64th Avenue
Arvada, Colorado
USA
Phone: +1 303 425 0800
Fax: +1 303 425 0896
E-mail: pumps@sundyne.com

European Sales Office

Sundstrand International, S.A.
13-15 Bd. Eiffel
Zone Industrielle de Dijon SUD
B.P. 30
21600 Longvic Cedex
France
Phone: +33 380 383300
Fax: +33 380 383336
E-mail: european-sales@sundyne.com

Sundyne Marelli Manufacturing

Ctra. Madrid-Toledo, Km. 30,8
45200 Illescas (Toledo)
Spain
Phone: +34 925 53 45 00
Fax: +34 925 51 16 00
E-mail: info@marellipumps.com

Members of: FLUIDEX, AFRE,
FENACORE, CEPREVEN, ATEX,
HYDRAULIC INSTITUTE

© 2009 Sundyne Corporation
All Rights Reserved
SM-DVMX-R.01 2009 Eng

To locate the global representative,
distributor or authorized service center
nearest you, or for additional information
please visit www.sundyne.com

GLOBAL STRENGTH, powered by people.